

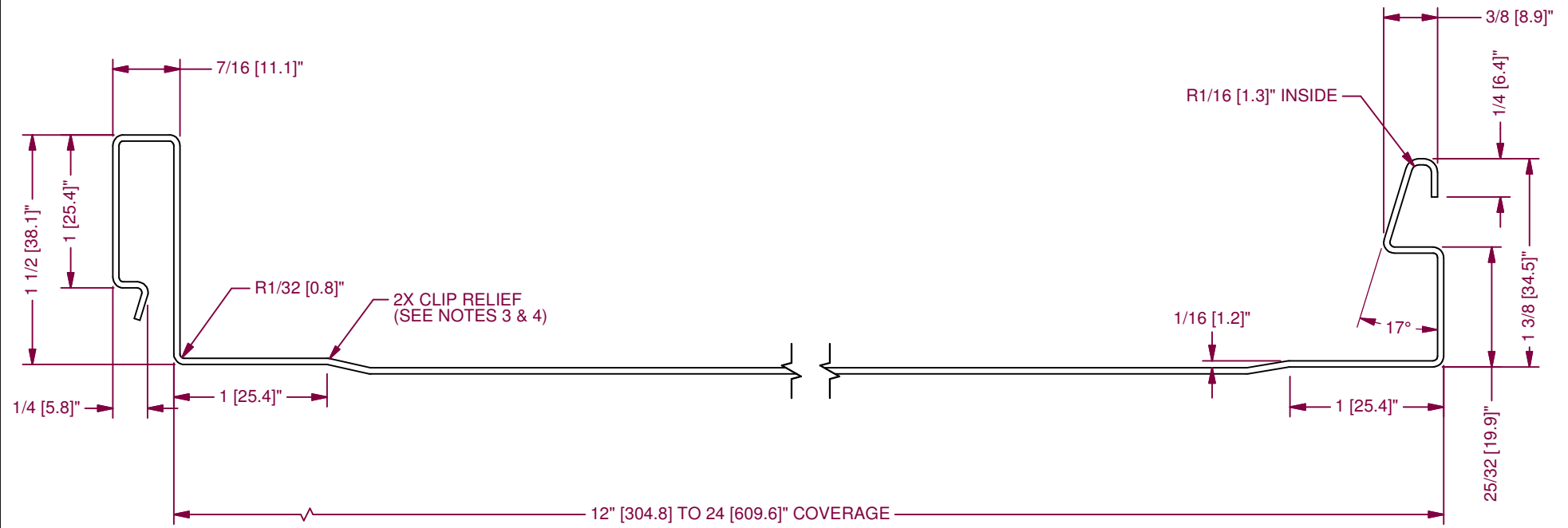

2

CREATED CLIP RELIEF VIEW

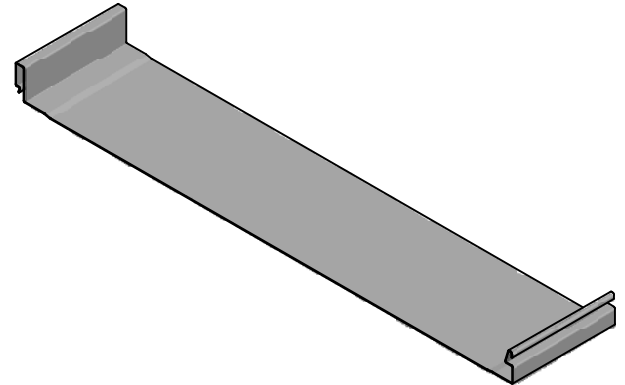

- NOTE:
1. MATERIAL USAGE: 5-1/8" [130.2]
  2. CLIP RELIEF ROLLERS ARE STANDARD WITH THIS PANEL.
  3. PANEL IS SHOWN WITH CLIP RELIEF ROLLERS ENGAGED.
  4. OPTIONAL MINOR BEAD RIB OR STRIATIONS AVAILABLE.
  5. DUAL DIMENSIONS: Inch [mm]

MATERIAL				PAINTED STEEL/PAINTED ALUMINUM/COPPER		FINISH		NONE		 <b>NEW TECH MACHINERY CORP.</b>	
REVISION HISTORY	REV	ECR NO.	DATE	RELEASED BY	TOLERANCES		DRAWN BY		PART NAME		
	1	ADDED mm	05/02/2012	JD	.XX = ± .01		GDP		SS550 PANEL PROFILE		
	2	R-2190			.XXX = ± .005		DATE				
						FRACTION = ± 1/32"		12-07-2009			
					ANGLE = ± 1/2'		CHECK BY		PART NUMBER		
							JD		SS5-550P		
							DATE		SHEET		
							05/02/2012		1 OF 1		
									REVISION		
									2		